



## For Delta reliability and single-lane economics, ASK FOR TCS MINI™

### Specially designed for

- Small processing plants
- Micro lots processing
- Specialty coffee preparations
- Reprocessing

### Versatile

- Capable of processing small batches of product at a time
- Small footprint

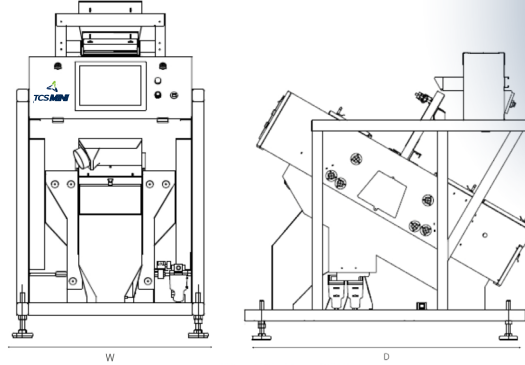

TCS sorters can be remotely accessed and controlled from any smartphone, tablet or PC.

### Technical Data

Model	Electrical	Air	Operating Temp.	Net Weight	W-Width	D-Depth	H-Height
TCS MINI-1	110 or 220 VAC 50 or 60 Hz single phase power 1.3 KW	26 CFM @ 100 PSI 0.7m <sup>3</sup> /minute @ 7 Bar	32°F - 104°F 0°C - 40°C	355Kg / 783Lbs	930mm / 37in	1574mm / 62in	1668mm / 66in
TCS MINI-2	110 or 220 VAC 50 or 60 Hz single phase power 1.5 KW	52 CFM @ 100 PSI 0.7m <sup>3</sup> /minute @ 7 Bar	32°F - 104°F 0°C - 40°C	550Kg / 1213Lbs	1244mm / 49in	1574mm / 62in	1668mm / 66in

Available in these configurations to meet your throughput and resort requirements: 63 and 126 channels.

## WORLD-WIDE ACCEPTANCE



## THE DELTA STORY

In business for more than 40 years under the same ownership, Delta color sorters offer greater accuracy, optimal product yields, and continual technological innovation. In 2018, we started incorporating artificial intelligence into our color sorters, allowing operational adjustments and performance tracking in real time.

Delta's "IntelliMax™" technology eliminates time-consuming manual calibration, with a fully automated user interface and immediate statistics on color defect recognition by type. Plus, our cloud-integrated platform allows both users and Delta technicians to remotely access, analyze, and adjust any of the world's most intelligent color sorters.



deltatechnology.com • 1602 Townhurst • Houston, Texas 77043 USA  
T 713.464.7407 • F 713.461.6753 • info@deltatechnology.com

©2024 Delta Technology Corporation. Manufactured under one or more USA and foreign patents pending or issued. Product specifications may change without notice.

